

RF-Audience! Product Description

Introduction,	2
Features and Benefits,	3
Flexible Configuration,	3
Enhanced Diagnostics,	3
Plug-and-Play Capability,	3
Sensitivity,	3
Standard Models,	5
Standard Models,	5
Technical Description,	7
Audience Control Module,	8
Power Supply Module,	9
Backplane,	11
Peripheral Options,	13
Bandpass Filter Option,	13
RF Distribution Option,	13
Network Peripheral Options,	13
GPS Receiver Option,	14
Specifications,	15

Introduction

Motorola's RF-Audience! (RF-A!) is a radio receiver designed specifically for reception of low-power signals from two-way pagers (see Figure 1). The RF-A! receives paging data, applies Inbound Paging Protocol (IPP) formatting, and forwards the data to the paging system for access by the caller or subscriber.

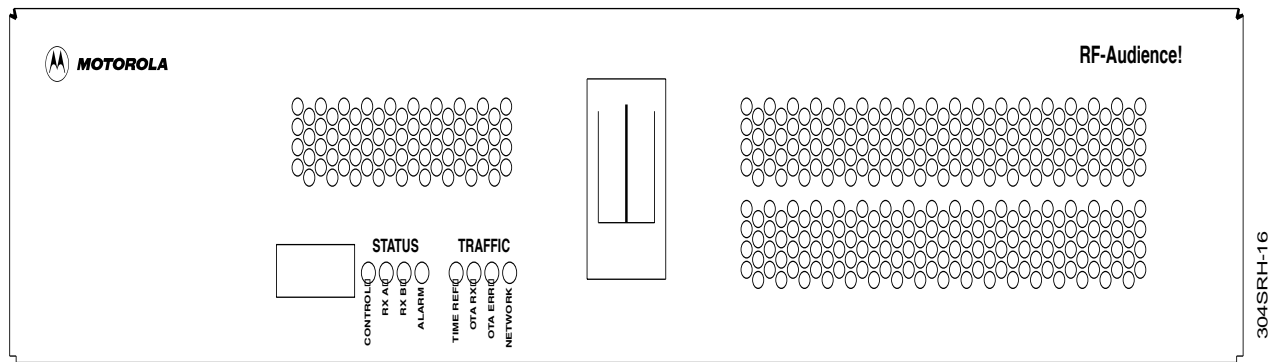

Figure 1: RF-A! Front Panel

The RF-A! embodies *Best In Class* solutions to critical two-way and data paging issues, including site costs, reliability, and ease of installation and maintenance. For example, RF-A! software upgrades can be downloaded remotely, saving costly and time-consuming site visits. Troubleshooting and diagnostic procedures also can be managed remotely with similar cost saving benefits.

But probably the most important feature of the RF-A! is its dual-port diversity design. This technological breakthrough increases the sensitivity of the receiver, and, as a consequence, reduces the number of receivers required in a network.

Features and Benefits

In order to attain our goal of *100 percent customer satisfaction*, the Motorola paging infrastructure team has made continuous quality improvement the centerpiece of its product design effort. Our goal is to ensure that the RF-Audience! (RF-A!) delivers the competitive advantages that our customers want—high reliability, reduced cost, and technologically advanced performance. Examples of the features we have introduced to support these objectives are described below.

Flexible Configuration

The RF-A! is designed to operate in a single 12.5-kHz inbound Narrowband PCS channel, and can be expanded to four channels over 50 kHz. The RF-A! can be co-located with a transmitter (RF-Orchestra! or Nucleus). This allows the sharing of site facilities and functions, such as network connections and GPS timing. The RF-A! is also available as a stand-alone unit for optimizing coverage areas. In either case, upgrading the system is as easy as adding one or more RF-A! base receivers.

Enhanced Diagnostics and Diagnostics

When coupled with the Choreographer!, the RF-A! offers a comprehensive diagnostics and alarm reporting capability. To maximize convenience when upgrading software, the RF-A! automatically accepts software downloads from the RF-Conductor!. The RF-A! diagnostics capability allows troubleshooting by searching error logs and manipulating parameter settings for paging functions such as:

- Network traffic
- Inbound Paging Protocol
- GPS
- RF synthesizer
- System clock
- Software download
- Bit error rate
- Alarm severity

Plug-and-Play Capability

The RF-A! has the ability to operate within a system that contains base receivers from more than one vendor. This gives the paging service provider the flexibility to use base receivers from different suppliers in the same system.

Sensitivity

The RF-A! is designed with the latest microprocessor and signal processing technology which achieves a level of receiver sensitivity far in excess of any alternative approach. The RF-A!'s dual-port diversity scheme uses two channels to receive the same signal, which allows the RF-A! to detect and correct

errors more effectively. The RF-A!'s two-channel scheme greatly increases the range of two-way pager transmissions, even as a transmitter's energy decreases. By reducing the number of receivers required in a system, the RF-A! reduces both initial investment and system operating costs.

Standard Models

Each RF-Audience! (RF-A!) is contained in a 19-inch wide, rack-mount chassis that is 3.5 inches (two rack units) high. Each receiver accepts signals on a single 12.5-kHz inbound channel in the 896 - 902 MHz range. The RF-A! front panel view is shown in Figure 1.

Four versions of the RF-A! are available for stand-alone sites:

PT1080A: One-channel receiver

PT1081A: Two-channel receiver

PT1082A: Three-channel receiver

PT1083A: Four-channel receiver

Peripheral options are also supported (see page 13, "RF-A! Peripheral Options"). Two different cabinet layouts are shown in Figure 2 and Figure 3. Similar configurations are available as options for the RF-Orchestra! linear transmitter, allowing for maximum site efficiency.

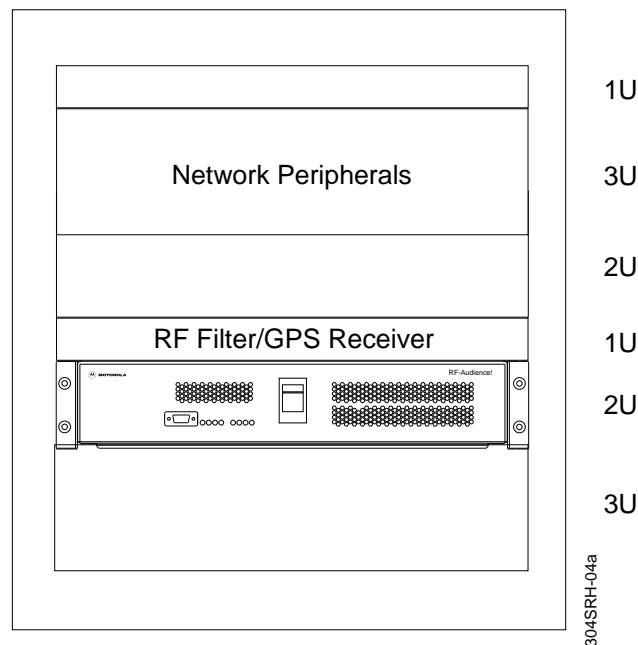

Figure 2: RF-A! One-channel Receiver, PT1080A, in a 25-inch Cabinet

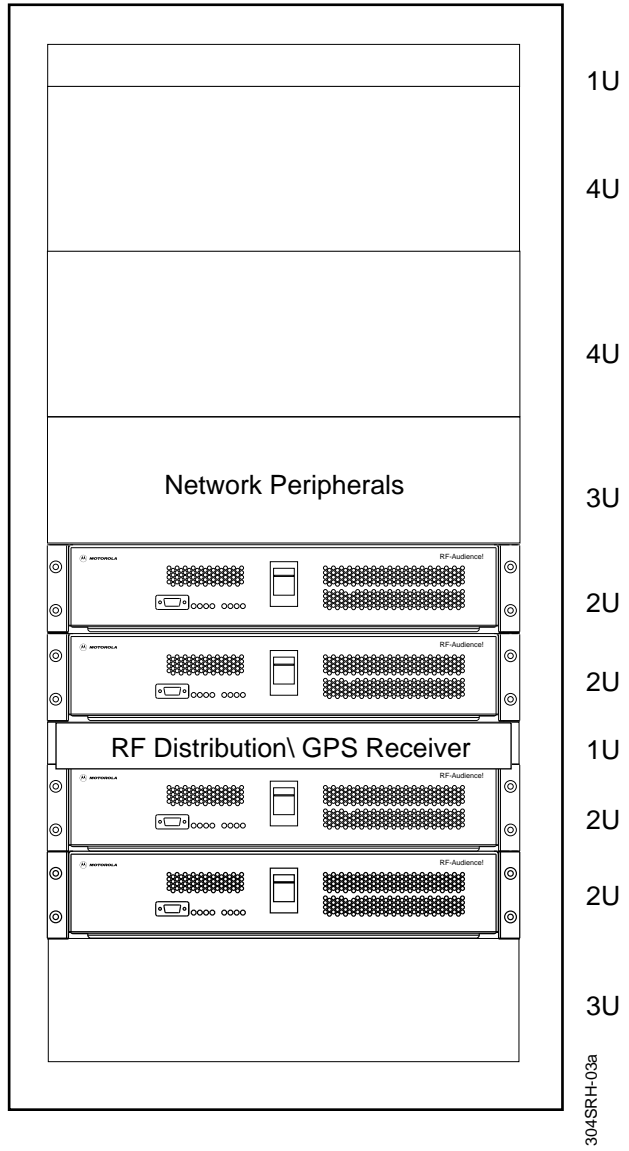

Figure 3: RF-A! Four-channel Receiver, PT1083A, in a 46-inch Cabinet

Technical Description

A basic RF-Audience! (RF-A!) consists of the following modules (see Figure 4):

- Two Receiver Modules (RFMs)
- One Audience Control Module (ACM)
- One AC power supply module

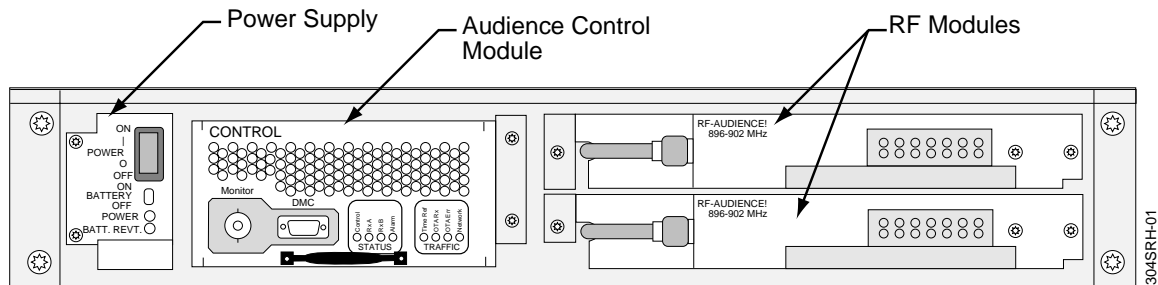

Figure 4: RF-A! Front Panel, Cover Opened

The two RFMs accept inbound Frequency Shift Keying (FSK) data on a single 12.5-kHz channel and convert it to baseband digital signals, which are then sent to the ACM.

The ACM's Digital Signal Processor (DSP) demodulates the incoming signals. The ACM selects receiver information with the best quality (microdiversity) and then applies IPP formatting before sending the message to the RF-C! controller through its network interface.

The AC power supply converts the line voltage to the levels required by the RF-A! circuitry.

The backplane provides interconnections with the various subsystems (see Figure 8).

Receiver Modules

The RF-A! contains two RFMs that receive 896-902 MHz signals from two-way pagers. Each RFM converts the RF signal to a digital signal and then sends the digital signal to the ACM for further processing (see Figure 5).

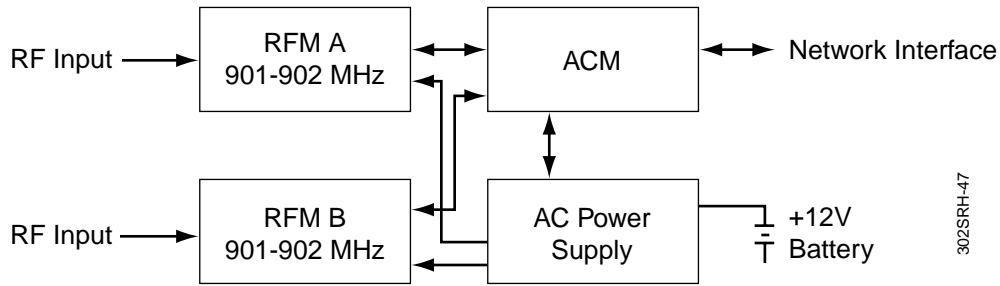

Figure 5: RF-A! Block Diagram

Input/Output

Each RFM has one front-panel and one rear-panel mini Ultra-High Frequency (UHF) connector that connects the RF input signal to the RFM. The two connectors are joined by a short co-axial cable. The rear-panel, 80-pin board edge connector is the RFM interface to the backplane (See Backplane on pg. 11).

Audience Control Module

The ACM provides the following:

- Control for each RFM
- Interface with external devices
- Reformatting of the RFMs' incoming messages to the IPP protocol
- Synchronizing all internal timing with the GPS signals

The ACM also monitors and processes RF-A! alarms and performs diagnostics on itself. Any detected problems are passed to the Choreographer!.

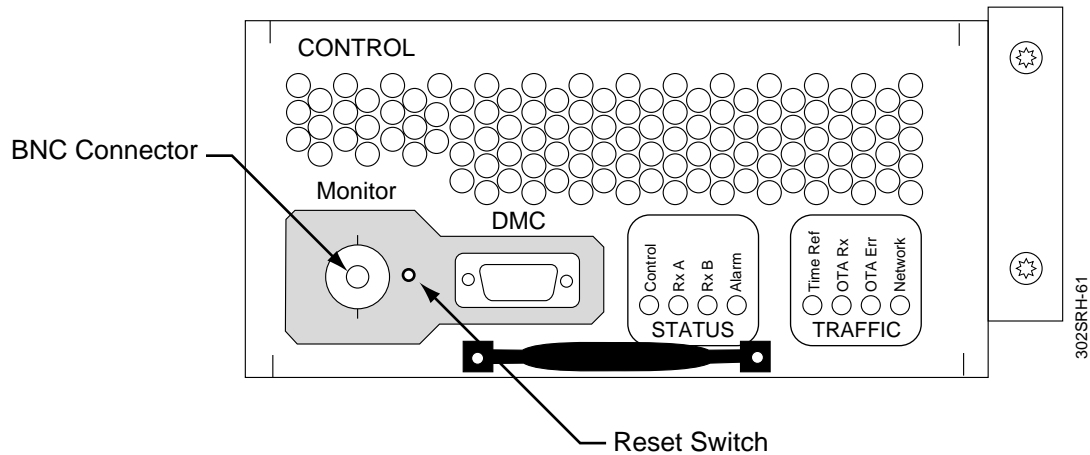

Figure 6: ACM Front View Showing Signal Monitor Port, DMC (FIPS) Port, and LED Indicators

LEDs located on the front of the ACM indicate the status of the RF-A! and the signal traffic conditions.

Controls and Indicators

The ACM provides a reset switch and eight LED status indicators (see Figure 6 and Table 1). The reset switch, when pressed momentarily, causes an ACM or restart.

Table 1: ACM Indicators

Indicator	Color	Description
Control	Green	Lights when the ACM is on and when it successfully completes its reset sequence
Rx A	Green	Lights when the Rx A (upper RFM synthesizer) is locked on frequency
Rx B	Green	Lights when the Rx B (lower RFM synthesizer) is locked on frequency
Alarm	Red	Lights when a station alarm has been detected
Time Ref		Lights when the GPS 1PPS signal is detected
OTA Rx		Lights when over-the-air data is correctly decoded
OTA Err		Lights when over-the-air data errors are detected
Network		Flashes to indicate network activity (normally on or normally flashing)

Input/Output

The ACM front-panel connections consist of a female BNC connector and a female DB9 serial port connector. The BNC connector serves as a scope connection for monitoring internal signals.

The Diagnostic, Maintenance, and Control (DMC) port is located on the front of the ACM (see Figure 6). Interaction between the service technician and the RF-A! is accomplished by connecting an external service monitor or terminal to this DB9 connector. A complete set of commands are provided so that the user can configure each receiver to its unique station parameters, perform hardware and software diagnostic procedures, and facilitate network and station management. The set of commands are collectively referred to as the Friendly Interface Protocol Specifications (FIPS).

Power Supply Module

The AC power supply module converts the incoming AC power (90 – 265 Vac, 47 – 63 Hz) to the DC power (+14.1 and +5.0 Vdc) used by the internal circuitry of the RF-A!.

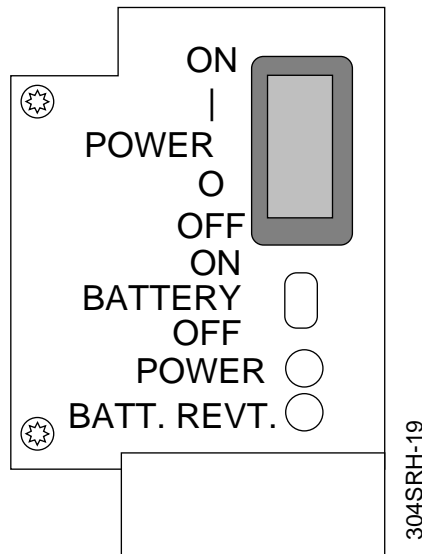

Figure 7: Power Supply Module—Front View

The power supply module provides several control mechanisms as well as LED status indicators (see Figure 7 and Table 2 and Table 3).

Table 2: Power Supply Controls

Control	Position	Description
POWER switch	ON	Applies AC power to the power supply module
	OFF	Removes AC power from the power supply module

Table 2: Power Supply Controls

Control	Position	Description
BATT switch	ON	Connects the backup battery to the power supply module
	OFF	Disconnects the backup battery from the power supply module

Table 3: Power Supply Indicators

Indicator	Color	Description
POWER	Green	Lights when the +14-Vdc and +5.1-Vdc outputs are present
BATT REVT	Yellow	Lights when the AC power is not present, and the power supply has reverted to battery backup

Backplane

The backplane provides a medium for intermodule communication and connections to external peripheral devices (see Table 4 and Figure 8).

Table 4: Backplane Connections

Connections	Description	Int/Ext Interface
J1	Power supply module	internal
J2	Audience Control Module (ACM)	internal
J3	RX A (upper RFM) 896-902 MHz *	internal
J4	RX B (lower RFM) 896-902 MHz *	internal
J5	Battery connect	external
J6	Network RS-232 port	external
J7	GPS/timing connector	external
J8	10-MHz reference	external
J9	UPS/battery status inputs	external
J10	Intrusion alarm input	ext
J11	Phone line connect	ext
J12	+5-Vdc, +14-Vdc peripheral power	ext
J13	+5-Vdc, +14-Vdc peripheral power	ext
J14	Ethernet AUI (not supported)	ext
J15	Auxiliary input/output (I/O)	ext

Note: * RX A was formerly identified as RX1, and RX B was formerly identified as RX0.

Figure 8 shows all external interfaces.

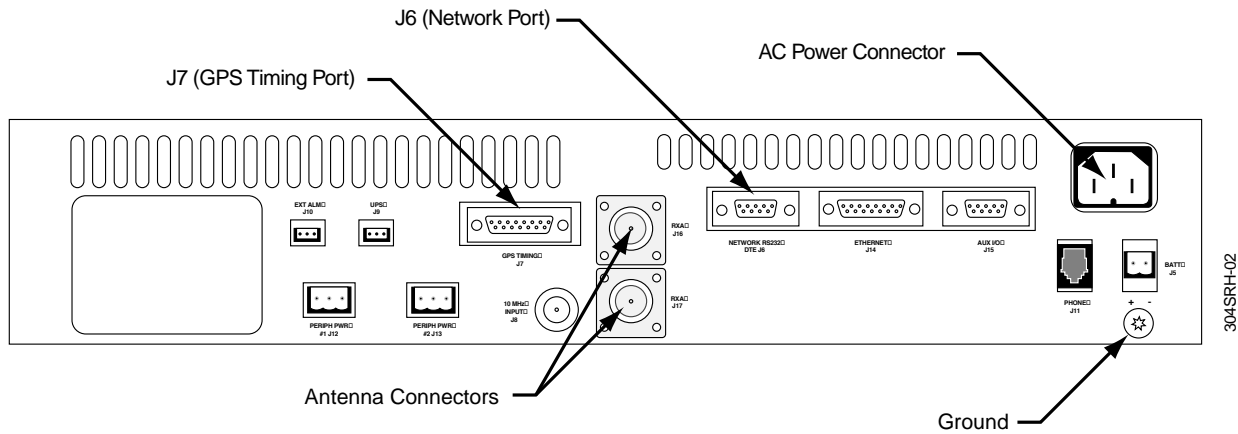

Figure 8: Backplane Rear Panel View

RF-A! Interfaces

The backplane of the RF-A! provides connectors for interfacing with other components in the system. A serial port located on the front of the ACM provides an interface for computer access to the receiver antenna connectors.

AC Power Connection

A 6-foot line cord with a 5-15P NEMA plug provides a connection to an appropriate AC power source.

Options

This section provides an overview of the options for the RF-Audience! (RF-A!). The RF-A! requires a GPS receiver and a network peripheral package to function in a system. While these peripherals are required, the actual peripheral is selectable. (Contact your Motorola representative for more information.)

The bandpass filters are not essential. However, bandpass filters improve overall performance by reducing external interference.

Bandpass Filter Option

RF filtering is recommended to minimize interference by RF-generating sources within a receiver's range. Two complete sets of cavity bandpass filters (one for each diversity receiver branch) are included with this option.

Two versions of the RF-A! RF filter option are available:

- X88AA: RF Filter (901-902 MHz)
- X88AB: RF Filter (901-902 MHz) with GPS receiver

RF Distribution Options

The RF distribution, or multicoupler, option allows multiple RF-A! receivers to operate with a single pair of receive antennas. The multicoupler includes two complete sets of cavity bandpass filters, low noise amplifiers, and five output splitter blocks. The RF distribution option allows up to four RF-A!s to operate with a pair of receiver antennas. See Figure 9 for a block diagram of the RF distribution option. Two versions of the RF-A! RF distribution option are available:

- X89AB: RF Distribution (901-902 MHz)
- X356AA: RF Distribution (901-902 MHz) with GPS receiver

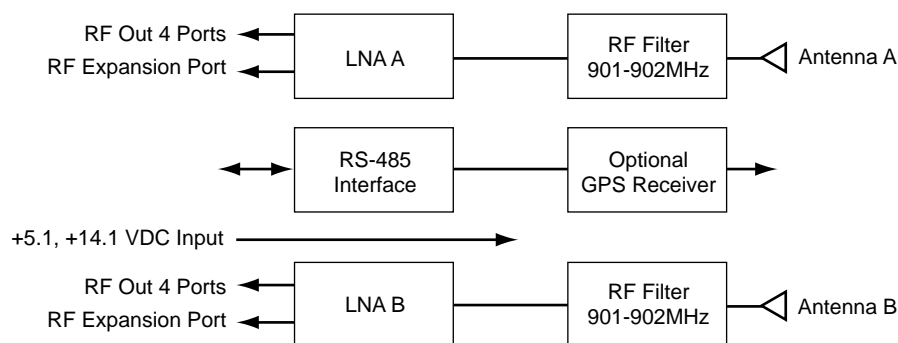

302SRH-64

Figure 9: RF Distribution Option Block Diagram

Network Peripheral Options

Several network peripheral options are available to allow communications between the RF-Audience! (RF-A!) site and RF-C! controller:

- Modems
- Router
- VSAT network

GPS Receiver Option

The GPS receiver detects signals from the U.S. Department of Defense NAV STAR GPS satellites, which uses the GPS timing for synchronization.

The RF-C! controller network requires a GPS receiver at the following locations:

- Each transmitter site
- Each stand-alone receiver site
- The RF-C! controller

The GPS receiver is configured to provide a highly accurate timing signal at precise, one-second intervals. The 1-pulse-per-second (1PPS) signal has a typical accuracy, with respect to Universal time, of +/- 150 nsec. In addition to the 1PPS signal, the GPS receiver provides the RF-A! with a time stamp (time and date) and additional status information.

A GPS receiver option is available on the RF Distribution and RF Filter options. The GPS receiver is also available as a stand-alone option (Option X243AD) mounted in a single-rack unit chassis. For receiver sites co-located with the RF-O! transmitter on the RF-B! transmitter controller, GPS timing signals can be obtained by appropriate connection to the RF-B! transmitter controller.

Specifications

The RF-Audience! (RF-A!'s) mechanical, electrical, and environmental specifications are provided in the following tables.

Table 5: Mechanical Specifications

Parameter	Specification
Standard mounting configuration	19-in. EIA cabinet
Width	19 in.
Depth	14 in.
EIA height	2 rack units (3.5 in.)
Weight	27.5 lb.
Network and RF peripheral accessories	Requires 3 to 6 rack units
1 RF-A! w/peripherals	Not to exceed 10 RU (17.5 in.)
4 RF-A! arrangement	
Receivers and RF distribution	Requires 9 rack units (15.75 in.)
Peripherals	Requires 3 to 6 rack units

Table 6: Electrical Specifications

Parameter	Specification
Frequency range	896.000–902.000 MHz
Channel spacing	12.5 kHz
Modulation	4-level FSK @ 800/1600 bps per ReFLEX/InFLEXion protocol
Sensitivity @ 800 bps¹	-128 dBm (at 1% packet error rate static)
Sensitivity @ 1600 bps¹	-125 dBm (at 1% packet error rate static)
Frequency generation	Synthesized @ 6.25 kHz
Frequency stability	± 1 ppm
Diversity	2-branch antenna diversity
IF frequencies	73.35 MHz, 450 KHz
Selectivity	70 dB @ 12.5 kHz
Intermodulation rejection	70 dB
Spurious and image rejection	90 dB
Off-channel acceptance	± 500 Hz
RF input VSWR	2.0:1 max (50 ohms ref)
Max input level (no damage)	+10 dBm

Table 6: Electrical Specifications

Parameter	Specification
Max input level (full spec)	-20 dBm
Noise figure	7.5 dB typical / 10 dB max at RX input
Emissions	FCC Class B
Input power	90–265 Vac, 47–63 Hz, single phase
Power supply type	Switched
Battery revert	12 V (optional)
Power consumption	35 watts (40 watts with RF peripheral)

1. RF-A!'s used with the RF Distribution option typically operate with sensitivities 2 db better than those shown.

Table 7: Environmental Specifications

Parameter	Specification
Temperature range	-30°C to +60°C(-22°F to +144°F)
Humidity	0 to 95% noncondensing @ 50°C